

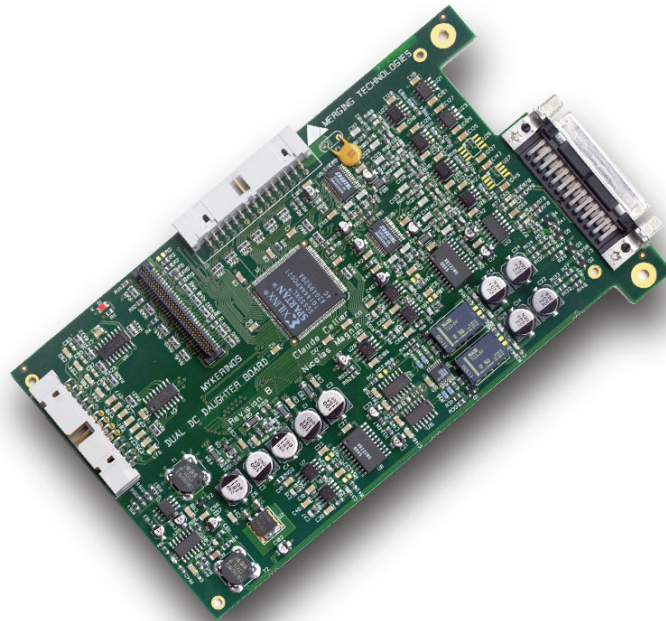

Mykerinos DUAL

Daughter card



User Manual

Version: DOC-1.1 (February 2009)
© 2009 Merging Technologies

Table of Contents

IMPORTANT NOTICE:	III
STATIC DANGER NOTICE:	III
INFORMATION FOR THE USER:	III
WARRANTY INFORMATION.....	IV
CONTACTING MERGING.....	IV
CHAPTER 1 – INTRODUCTION	1
CARD FEATURES	1
CARD OVERVIEW	1
CHAPTER 2 – INSTALLATION	2
MOUNTING THE DUAL DAUGHTER CARD ON MYKERINOS.....	2
CONNECTING THE AES/EBU EXTENSION BRACKET.....	2
INSTALLING THE MYKERINOS-DUAL CARD ON YOUR COMPUTER	2
CHAPTER 3 – BRACKET CONNECTIONS	3
BRACKET CONNECTORS.....	3
MYKERINOS MONITOR OUTPUT	3
MYKERINOS VIDEO/TC I/O	3
DUAL ANALOG I/O	4
DUAL AES/EBU I/O.....	4
CHAPTER 4 – SOFTWARE SETTINGS	5
REFERENCE SELECTION.....	5
INPUT GAIN SELECTION.....	6
MIC/LINE SELECTION	6
48V SELECTION.....	6
MICPREAMP GAIN SELECTION	6
OUTPUT GAIN SELECTION	6
OUTPUT MUTE SELECTION.....	6
CHAPTER 5 – TYPICAL AUDIO SETUP	7
APPENDIX 1 – TECHNICAL SPECIFICATIONS	8
ANALOG LINE INPUTS	8
MICROPHONE PREAMPLIFIERS.....	8
ANALOG LINE OUTPUTS.....	8
AES/EBU INPUTS	8
AES/EBU OUTPUTS.....	8
APPENDIX 2 –BLOC DIAGRAM	9
APPENDIX 3 – BREAKOUT CABLES SPECIFICATION	10
BREAKOUT CABLES CONNECTORS	10
ANALOG I/O BREAKOUT CABLE.....	10
AES/EBU I/O BREAKOUT CABLE	10

IMPORTANT NOTICE:

Please read the following information very carefully before attempting any installation. Failure to comply with the precise instructions may result in damage to your Merging hardware. Please read this entire section of the manual carefully before installation.

STATIC DANGER NOTICE:

Please note that the DUAL Daughter card contains delicate electronic components that can be damaged or even destroyed when exposed to static electricity. Take all necessary precautions not to discharge static electricity when touching any of the DUAL Daughter card components.

INFORMATION FOR THE USER:

Mykerinos and its daughter card comply with the following specifications:

EMC Emissions

EN 55022 : 1994 /A1 : 1995 /A2 : 1997 Class A ITE emissions requirements (EU)

FCC 47 CFR Part 15 Class A emissions requirements (USA)

EMC Immunity

EN 50082-1: 1992 EMC residential, commercial and light industrial generic immunity standard.

FCC Notice

This product has been tested and found to comply with the limits for a Class A digital device, pursuant to Part 15 of the FCC rules. Operation is subject to the following two conditions: (1) This device may not cause harmful interference, and (2) This device must accept any interference received, including interference that may cause undesired operation.

These limits are designed for providing reasonable protection against harmful interference in a residential installation. This equipment generates, uses and can radiate radio frequency energy and, if not installed and used in accordance with the instructions contained in this manual, may cause harmful interference to radio and television communications. However, there is no guarantee that interference will not occur in a particular installation.

NOTE: Connecting this device to peripheral devices that do not comply with CLASS A requirements or using an unshielded peripheral data cable could also result in harmful interference to radio or television reception. The user is cautioned that any changes or modifications not expressly approved by the party responsible for compliance could void the user's authority to operate this equipment. To ensure that the use of this product does not contribute to interference, it is necessary to use shielded I/O cables.

CE Notice

Such a  marking is indicative that this system's devices meet the following applicable technical standards:

- EN 55022 – “Information Technology Equipment - Radio disturbance characteristics Limits and methods of measurement”
- EN 50082-1: 1992 – “Electromagnetic compatibility – Generic immunity standard Part 1: Residential, commercial, and light industry”

This product is classified for use in a typical Class A commercial environment, and is not designed or intended for use in other EMC environments. The user of this product is obliged for proper use and installation of the product and for taking all steps necessary to remove sources of interference to telecommunications or other devices.

Warranty Information

This product is warranted to be free of defects in materials and workmanship for a period of one year from the date of purchase. Merging Technologies, Inc. extends this Limited Warranty to the original purchaser.

In the event of a defect or failure to conform to this Limited warranty, Merging Technologies, Inc. will repair or replace the product without charge within sixty (60) days. In order to make a claim under this limited warranty, the purchaser must notify Merging Technologies, Inc. or their representative in writing, of the product failure. In this limited warranty the customer must upon Merging Technologies, Inc. request, return the product to the place of purchase, or other local designation, for the necessary repairs to be performed. If the consumer is not satisfied with the repair, Merging Technologies, Inc. will have the option to either attempt a further repair, or refund the purchase price.

This warranty does not cover: (1) Products which have been subject to misuse, abuse, accident, physical damage, neglect, exposure to fire, water or excessive changes in the climate or temperature, or operation outside maximum rating. (2) Products on which warranty stickers or product serial numbers have been removed, altered or rendered illegible. (3) The cost of installations, removal or reinstallation. (4) Damages caused to any other products.

Contacting Merging

For all general or sales inquiries:

In Europe, Africa and Asia contact our Swiss Office:

Merging Technologies SA
Le Verney 4
1070 Puidoux
Switzerland

Phone: +41 21 946 0444
Fax: +41 21 946 0445

In the Americas, contact our US Office:

Independent Audio, Inc.
43 Deerfield Road
Portland, ME 04101-1805
United States of America

Phone: +1 207 773 2424
Fax: +1 207 773 2422

Merging website: www.merging.com

Chapter 1 – Introduction

Congratulations on your Mykerinos DUAL Daughter card purchase. The Dual DC is the most cost-effective I/O daughter card for Pyramix, Incite Studio and SOFTIMAGE®|DS users, as well as for OEMs. It is an ideal I/O solution for mixed analog/digital requirements, as encountered in Broadcast production, and Video/Film post-production environments. It allows the direct connecting of up to two electrodynamic or condenser microphones, typically for quick and easy voice-over recording.

Card Features

- Up to 12 inputs and 12 outputs on a single board:
 - > 2 CH Analog Mic/Line inputs
 - > 2 CH Analog Line inputs
 - > 4 CH Analog Line outputs
 - > 8 CH AES/EBU inputs
 - > 8 CH AES/EBU outputs
- All audio connections are made using high-quality balanced XLR type connectors, provided by two DB-25 break-out cables.
- High quality 24 bit A/D and D/A using the latest generation in converter technology.
- 2 built-in microphone preamplifiers, with a selection MIC / LINE available on analog inputs 1 and 2.
- Built-in 48V microphone phantom power.
- Analog input and output level adjustment offering 24 dB range to accommodate all standard studio levels.
- High common mode rejection balanced input circuitry on all analog inputs, for optimum rejection of power line hum, RF interference, voltage drops and other externally generated noise commonly encountered with long audio cable runs.
- High quality balance output circuitry on all analog outputs, for maximum output signal balance ratio performance, even under adverse asymmetrical loads.
- Support for sampling rates 32 kHz, 44.1 kHz or 48 kHz.
- High cost-effectiveness.

Card Overview

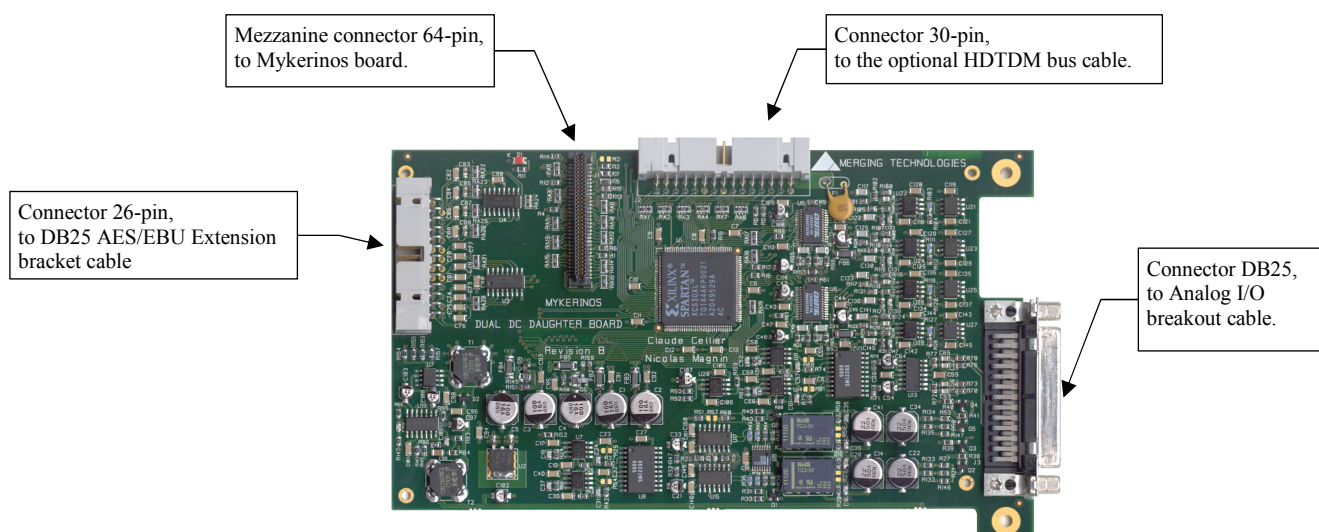

Chapter 2 – Installation

Mounting the DUAL daughter card on Mykerinos

If your DUAL Daughter card is already assembled with your Mykerinos board, you can jump to the next point.

To change your Mykerinos Daughter card:

- Remove the daughter card to be changed, if any
- If necessary, remove the Mykerinos bracket,
Mount in its place the bracket shipped along with your DUAL Daughter card,
- Place your DUAL Daughter card on Mykerinos:
 - First insert the Analog I/O DB25 connector into its corresponding bracket opening,
 - Then place the Mezzanine connector carefully in front of its corresponding connector on Mykerinos,
 - Gently press the two boards against each other, until the connectors are tightly fitted,
 - Mount the 4 screws correctly to ensure a good electrical connection between both boards.

Connecting the AES/EBU extension Bracket

Plug your DB25 AES/EBU Extension bracket cable into the corresponding 26-pin connector on the rear of your Mykerinos-DUAL PCI card.

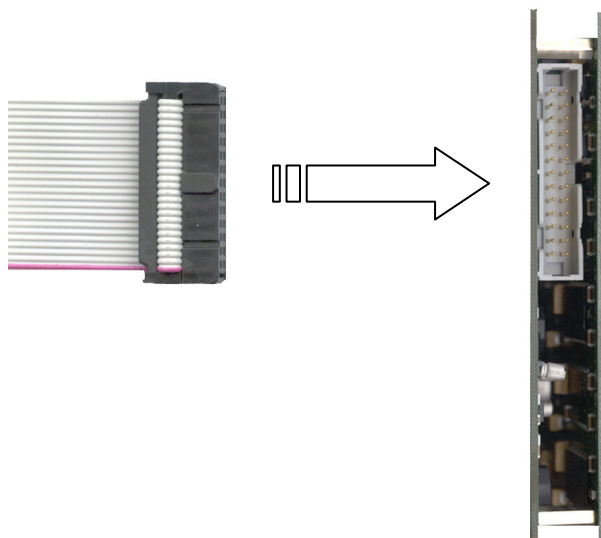

Installing the Mykerinos-DUAL card on your computer

You need to find two free slots to install the Mykerinos-DUAL board and its AES/EBU Extension bracket:

- The Mykerinos-DUAL board need a free PCI slot,
- The AES/EBU Extension bracket can be placed on any free slot,
You can also mount it on any DB25 opening available in your PC Box, in case you are short of free slot.

Correctly mount the brackets and DB25 screws, to ensure a good electrical connection to the PC Box.

Chapter 3 – Bracket Connections

Bracket connectors

The following figure represents the Mykerinos bracket when combined with the DUAL Daughter card, and the DUAL AES/EBU Extension bracket.

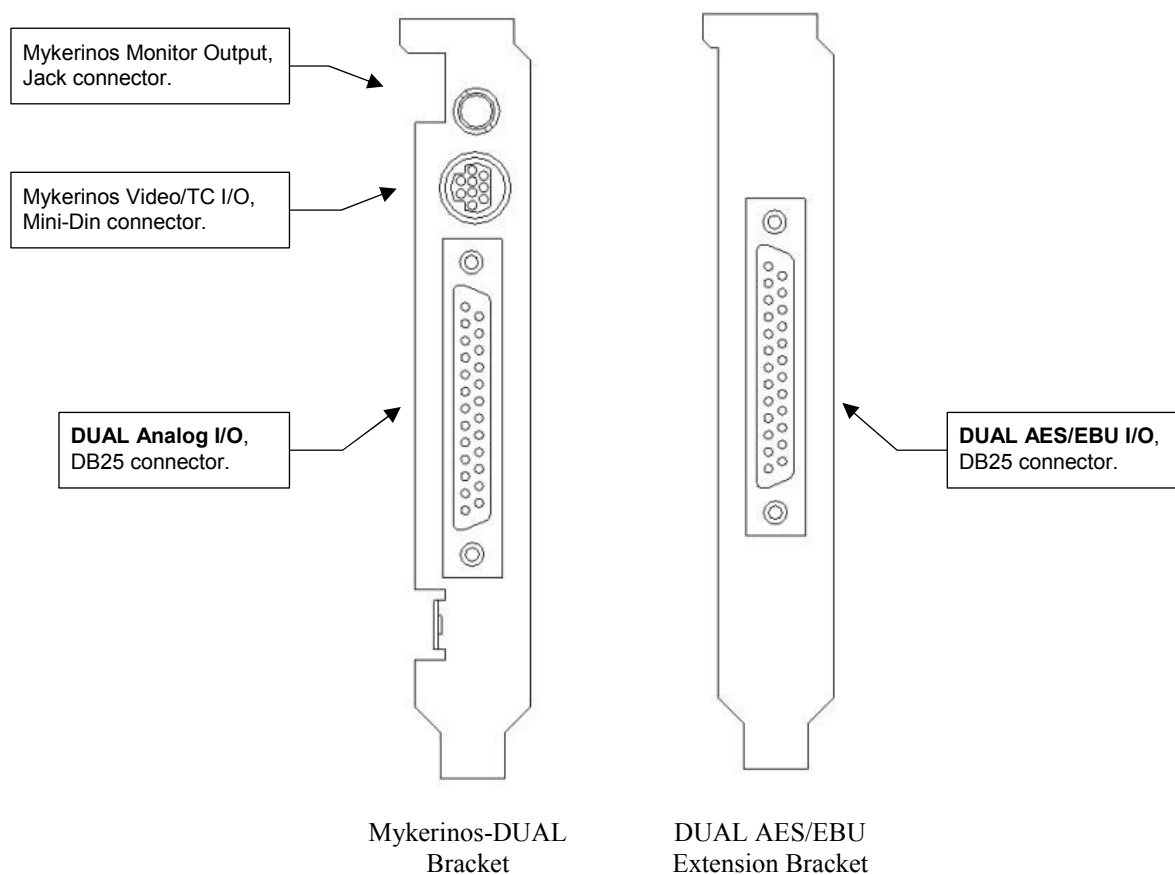

Mykerinos Monitor Output

This is the unbalanced stereo output corresponding to the “Monitor Jack” Left / Right output channels of your mixer. Any headphone or preamplifier can be connected to this output.

See “Mykerinos User Manual” for detailed information on the Monitor Output.

Mykerinos Video/TC I/O

This 9-pin Mini-Din connector is for the Mykerinos Video/TC breakout cable.

The breakout cable allows Mykerinos to lock to a video “house sync” or a Wordclock reference, read & generate VITC and read & generate LTC. This option also adds the capability to “burn” a Time code “insert” in the video output signal. This interface has provision for one BNC input CVS1In, one BNC Input/Output CVS2In/WCK, one BNC output CVS Out, one XLR Female for LTC input and one XLR Male for LTC output.

See “Mykerinos User Manual” for detailed information on the Video/TC I/O.

DUAL Analog I/O

This DB25 connector is for the DUAL Analog I/O breakout cable, as shown in the following drawing.

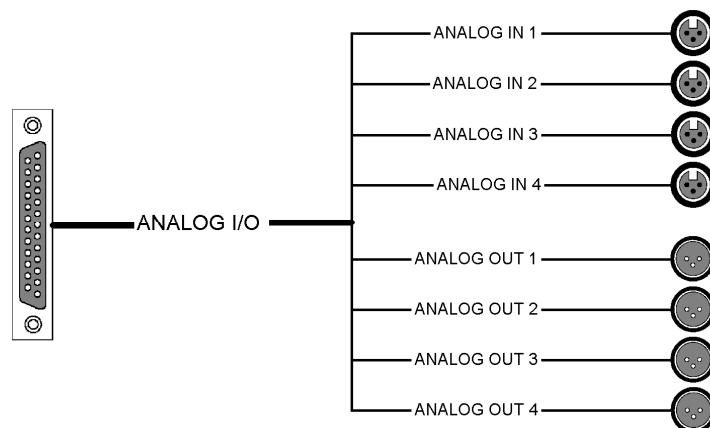

See Appendix 3 for detailed information on breakout cables.

ANALOG IN 1 - 4

Any professional level balanced audio output can be connected to the analog line inputs of the DUAL Daughter card. Input levels are selectable from consumer level (-10 dBV) up to professional level (+4 dBu). See chapter 4 on how to adjust the *Analog Input Levels*.

ANALOG OUT 1 - 4

Any professional level balanced audio input can be connected to the analog line outputs of the DUAL Daughter card. Output levels are selectable from consumer level (-10 dBV) up to professional level (+4 dBu). See chapter 4 on how to adjust the *Analog Output Levels*.

DUAL AES/EBU I/O

This DB25 connector is for the DUAL AES/EBU I/O breakout cable, as shown in the following drawing.

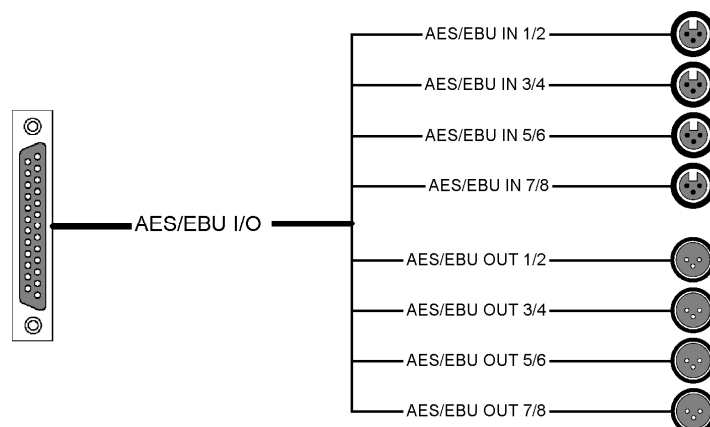

See Appendix 3 for detailed information on breakout cables.

AES/EBU IN 1/2 - 7/8

Any professional level balanced digital AES/EBU audio output sources at 32, 44.1 or 48 KHz can be connected to the AES/EBU inputs of the DUAL Daughter card.

AES/EBU OUT 1/2 - 7/8

Any professional level balanced digital AES/EBU audio inputs at 32, 44.1 or 48 KHz can be connected to the AES/EBU outputs of the DUAL Daughter card.

Chapter 4 – Software Settings

To access the DUAL Software Settings:

- Open the “Mixer Settings” panel.
- Select the “DUAL(#10xxx)” tab.

The following settings panel appears:

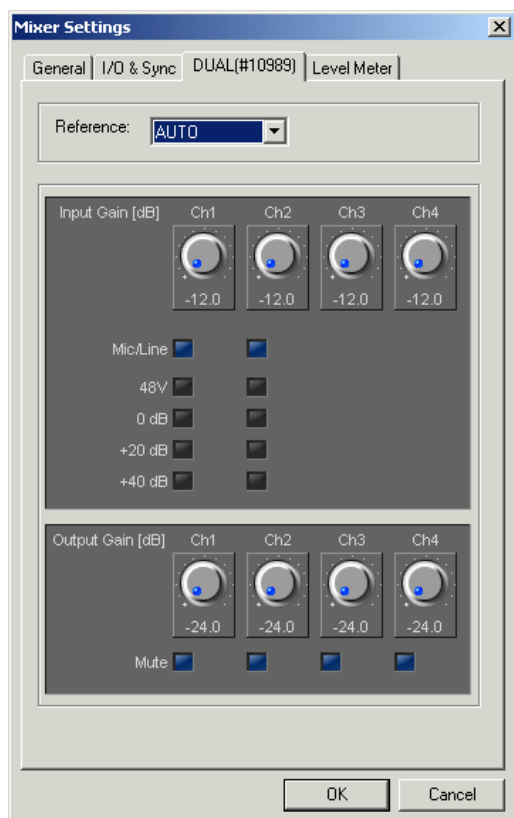

Reference Selection



This field allows the selection of the “Audio Input” sync source.

When “Audio Input” is selected as sync source in “I/O & Sync” tab, DUAL will chose the AES/EBU input to which synchronize depending on the sync mode selected.

There are five possible sync modes:

- AUTO
- AES/EBU (1/2)
- AES/EBU (3/4)
- AES/EBU (5/6)
- AES/EBU (7/8)

While in AUTO mode, DUAL automatically detects and switches to a valid AES/EBU sync source.

In the four other modes, DUAL always tries to synchronize to the specified input. It never switches to another input, even when the selected sync source becomes invalid.

Input Gain Selection



This section allows analog input level adjustment.

To accommodate your external devices output levels, you can change the input level of each analog input within a range of -12 dB to +12 dB.

A gain of -12 dB will result in a +20 dBu full scale input level.

A gain of +12 dB will result in a -4 dBu full scale input level.

Mic/Line Selection

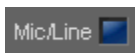

This section allows the enabling of the microphone preamplifier.

This option is available on analog inputs 1 and 2 only.

Check this option if you want to connect an electrodynamic or a condenser microphone to the corresponding input.

48V Selection



This section allows the enabling of the 48V phantom power.

This option is available only if the "Mic/Line" option is selected on the corresponding input.

Check this option if you want to connect a 48V condenser microphone to the corresponding input.

MicPreamp Gain Selection

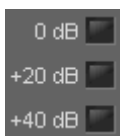

This section allows the selection of the microphone preamplifier gain.

This option is available only if the "Mic/Line" option is selected on the corresponding input.

You can select 0 dB, +20 dB or +40 dB, depending on your microphone sensitivity.

Output Gain Selection



This section allows analog output level adjustment.

To accommodate your external devices input levels, you can change the output level of each analog output within a range of -24 dB to 0 dB.

A gain of -24 dB will result in a -6 dBu full scale output level.

A gain of 0 dB will result in a +18 dBu full scale output level.

Output Mute Selection



This section allows the enabling of the analog output mute.

Selecting this option make sure that the corresponding analog output will always be muted, even if your mixer routes audio to this output.

Chapter 5 – Typical Audio Setup

This section displays typical audio connections for Merging Mykerinos-DUAL in a Video environment.

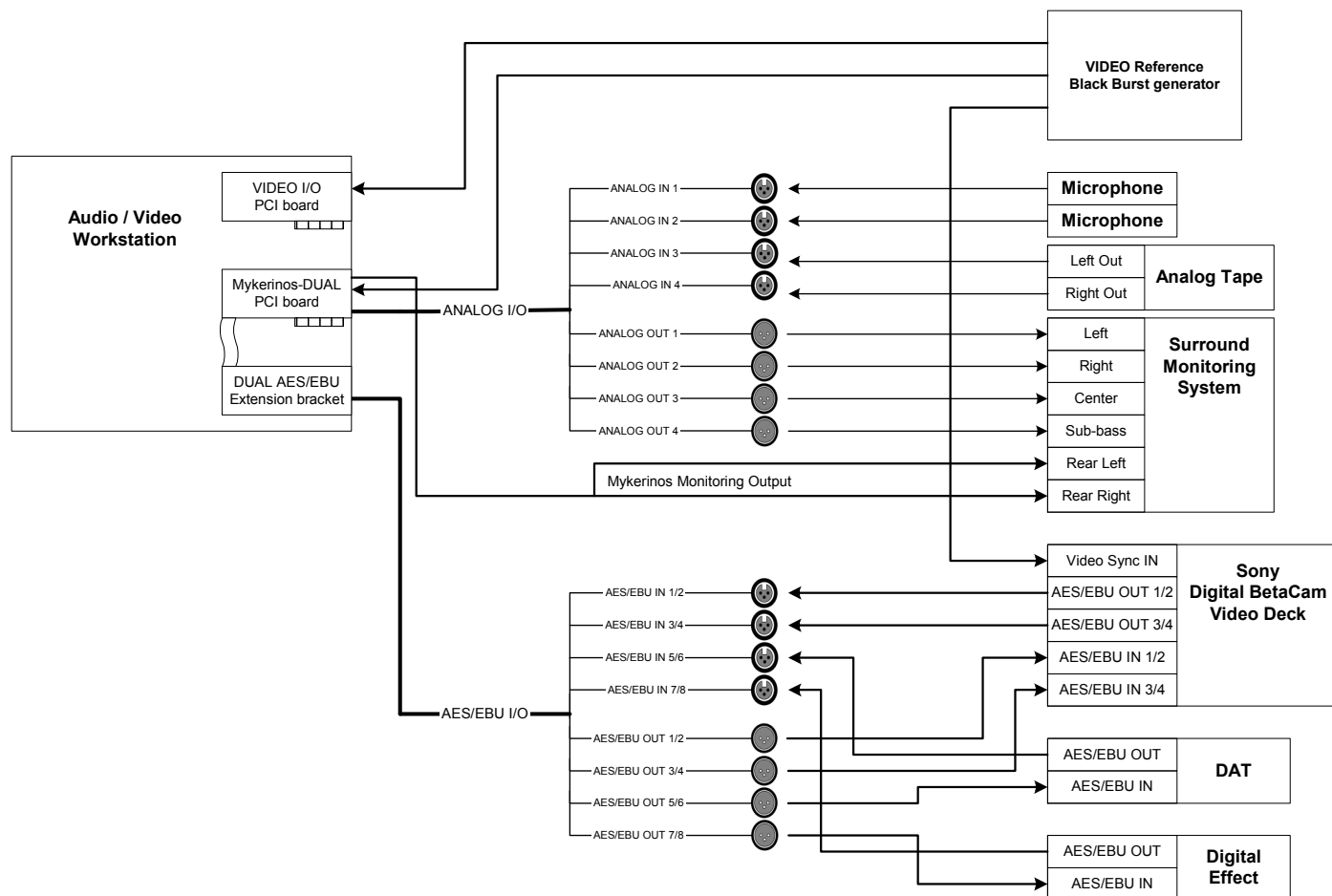

This example uses the following:

- Digital BetaCam AES/EBU outputs are connected to DUAL AES/EBU IN 1/2 and 3/4.
- DUAL AES/EBU OUT 1/2 and 3/4 are connected to Digital BetaCam AES/EBU inputs.
- The DAT AES/EBU output is connected to DUAL AES/EBU IN 5/6.
- DUAL AES/EBU OUT 5/6 is connected to the DAT AES/EBU input.
- The Digital Effect AES/EBU output is connected to DUAL AES/EBU IN 7/8.
- DUAL AES/EBU OUT 7/8 is connected to the Digital Effect AES/EBU input.
- Two Microphones are connected to DUAL Analog IN 1 and 2.
- An analog stereo tape or a camera is connected to DUAL Analog IN 3 and 4.
- The Surround Monitoring system uses DUAL Analog OUT 1-4 for the Left, Right, Center and Sub-Bass channels. The Rear Left and Rear Right channels are provided by the Mykerinos Monitoring Output.
- The Mykerinos card (via the VIDEO/TC breakout cable), the Video I/O card and the Video Deck are connected to the Video Reference “Black Burst” generator.
Note that each device should be connected to the video generator with its own cable.
Using the Loop-Through to connect the different devices is not recommended.
- The Mykerinos is set to lock to “Video”, or “Audio Input” with DUAL configured in “AUTO” sync mode.

Appendix 1 – Technical Specifications

Parameter	Conditions	Value	Unit
Power Consumption	+3.3V	< 100	mA
	+5V	< 200	mA
	+12V	< 300	mA
	-12V	< 100	mA

Analog Line Inputs

Parameter	Conditions	Value	Unit
Resolution		24	Bits
Max. Sample Rate		48	KHz
Min. Full Scale Input Level		-4	dBu
Max. Full Scale Input Level		+20	dBu
Dynamic Range	A-weighted	102	dB(A)
	20Hz-20kHz	98	dB
THD+N	1 kHz @ -1 dBFS = +17 dBu	-93	dB
Frequency Response	20Hz-20kHz	± 0.1	dB
Input Impedance	Differential	>13	KOhms
Common Mode Rejection		>40	dB
Interchannel Isolation (Crosstalk)	1kHz	>100	dB

Microphone Preamplifiers

Parameter	Conditions	Value	Unit
Dynamic Range	Gain = 0 dB (A-weighted)	102	dB(A)
(Including A/D converter)	Gain = +20 dB (A-weighted)	96	dB(A)
	Gain = +40 dB (A-weighted)	77	dB(A)
Phantom Power selection		+48	V
Input Impedance	Differential	>3	KOhms

Analog Line Outputs

Parameter	Conditions	Value	Unit
Resolution		24	Bits
Max. Sample Rate		48	KHz
Min. Full Scale Output Level		-6	dBu
Max. Full Scale Output Level		+18	dBu
Dynamic Range	A-weighted	97	dB(A)
	Unweighted	95	dB
THD+N	1 kHz @ -1 dBFS = +17 dBu	-93	dB
Frequency Response	20Hz-20kHz	± 0.1	dB
Output Impedance	Differential	<50	Ohms
Output Balance Ratio		>40	dB
Interchannel Isolation (Crosstalk)	1kHz	>100	dB

AES/EBU Inputs

Parameter	Conditions	Value	Unit
Resolution		24	Bit
Max. Sample Rate		48	KHz
Input Impedance	Differential	110	Ohms

AES/EBU Outputs

Parameter	Conditions	Value	Unit
Resolution		24	Bit
Max. Sample Rate		48	KHz
Output Impedance	Differential	110	Ohms

Note: All specifications subject to change without notice.

Appendix 2 –Bloc Diagram

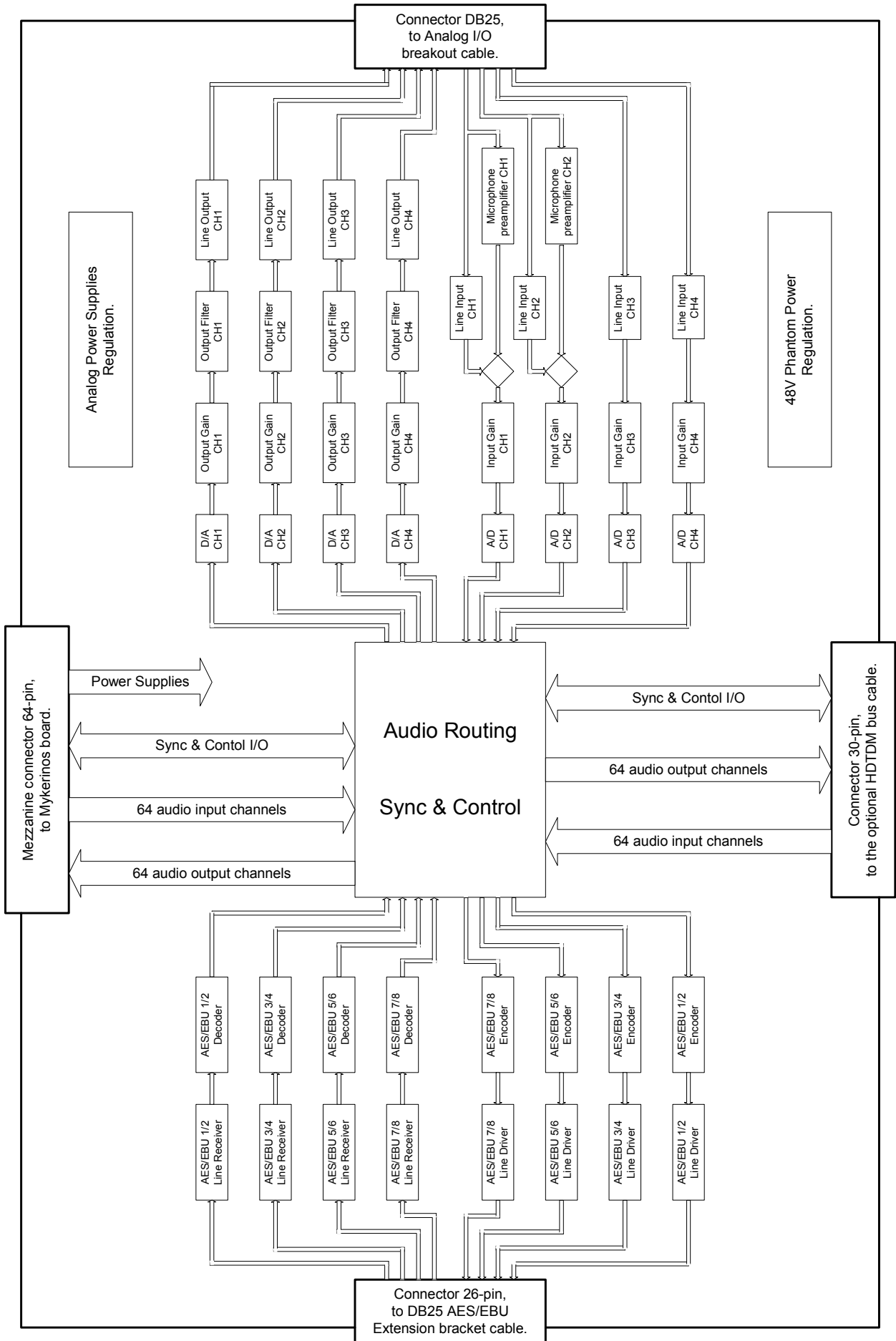

Appendix 3 – Breakout cables Specification

Breakout cables connectors

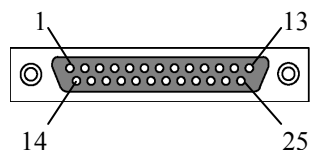

DB25 Male Connector (I/O)

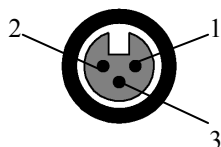

XLR Female Connector (Inputs)

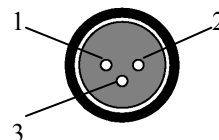

XLR Male Connector (Outputs)

Analog I/O breakout cable

XLR Label	XLR color	Signal	XLR-F	DB25-M	XLR Label	Cable Color	Signal	XLR-M	DB25-M
ANALOG IN 1	BROWN	AGND	1	9	ANALOG OUT 1	GREEN	AGND	1	5
		AIN1+	2	13			AOUT1+	2	1
		AIN1-	3	25			AOUT1-	3	14
ANALOG IN 2	RED	AGND	1	21	ANALOG OUT 2	BLUE	AGND	1	18
		AIN2+	2	12			AOUT2+	2	2
		AIN2-	3	24			AOUT2-	3	15
ANALOG IN 3	ORANGE	AGND	1	8	ANALOG OUT 3	PURPLE	AGND	1	6
		AIN3+	2	11			AOUT3+	2	3
		AIN3-	3	23			AOUT3-	3	16
ANALOG IN 4	YELLOW	AGND	1	20	ANALOG OUT 4	GRAY	AGND	1	19
		AIN4+	2	10			AOUT4+	2	4
		AIN4-	3	22			AOUT4-	3	17

Note: The DB25 pin 7 is connected to AGND.

AES/EBU I/O breakout cable

XLR Label	XLR Color	Signal	XLR-F	DB25-M	XLR Label	XLR Color	Signal	XLR-M	DB25-M
AES/EBU IN 1/2	BROWN	DGND	1	9	AES/EBU OUT 1/2	GREEN	DGND	1	5
		DIN1/2+	2	13			DOUT1/2+	2	1
		DIN1/2-	3	25			DOUT1/2-	3	14
AES/EBU IN 3/4	RED	DGND	1	21	AES/EBU OUT 3/4	BLUE	DGND	1	18
		DIN3/4+	2	12			DOUT3/4+	2	2
		DIN3/4-	3	24			DOUT3/4-	3	15
AES/EBU IN 5/6	ORANGE	DGND	1	8	AES/EBU OUT 5/6	PURPLE	DGND	1	6
		DIN5/6+	2	11			DOUT5/6+	2	3
		DIN5/6-	3	23			DOUT5/6-	3	16
AES/EBU IN 7/8	YELLOW	DGND	1	20	AES/EBU OUT 7/8	GRAY	DGND	1	19
		DIN7/8+	2	10			DOUT7/8+	2	4
		DIN7/8-	3	22			DOUT7/8-	3	17

Note: The DB25 pin 7 is connected to DGND.